



REX POWER MAGNETICS

A DIVISION OF TRANSFACTOR INDUSTRIES INC.  
65 BASALTIC RD, CONCORD, ON, CA L4K 1G4  
TEL: 905-695-8844 • FAX: 905-695-8855  
WWW.REXPOWERMAGNETICS.COM

### TRANSFORMER SPECIFICATION

- 3 Phase Auto
- Dry Type
- ANN -Self cooled

Purchaser: TBA  
 PO#: TBA  
 SWO#: TBA  
 Qty: TBA

Coils: Copper  
 Cat. No.: RC300J-H  
  
 kVA: 300  
 Primary: 600 Volts  
 Secondary: 480 Volts  
  
 Frequency: 60 Hz  
  
 Insulation Class: 220° C  
 Temperature Rise: 150° C  
  
 Weight: 535 Lbs

Termination	Location	Terminals
Primary:	Front	600MCM-2
Secondary:	Front	Pads

#### Wiring Connection:

**Primary:**  
 Voltage 600  
 Connect Lines To: H1-H2-H3

**Secondary:**  
 Voltage 480  
 Connect Loads To: X1-X2-X3

### Preliminary Drawing ONLY

This drawing may NOT truly reflect our final design.  
 Any resulting order(s) must be accompanied by or refer to this drawing and be marked with any proposed changes

#### Standards:

1. CSA Certified  
 - File No. LR34493
2. UL Listed  
 - File No. E108255

#### Standard Features:

1. Anti-vibration pads installed between the enclosure base and the core & coil assembly
2. Lug for Earth Grounding provided

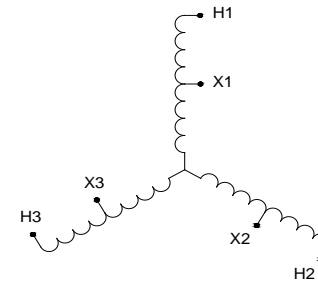
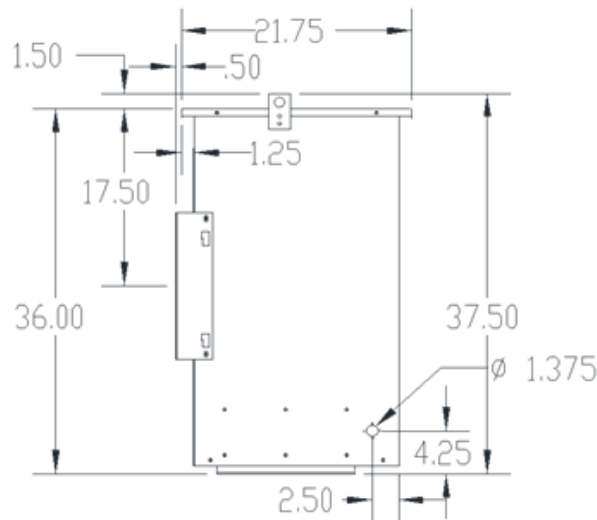
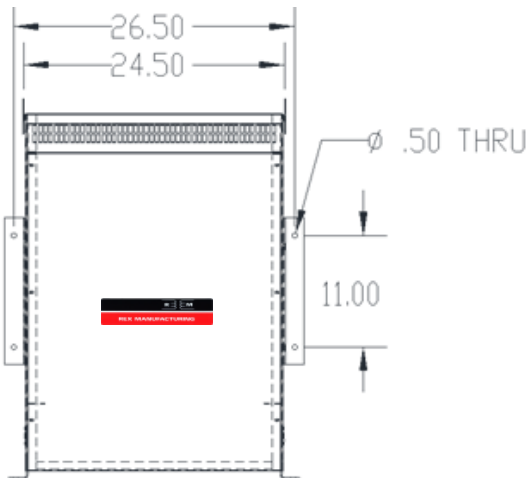

#### CSA Enclosure:

1. Type 3R (NEMA 3R)  
 - Sprinklerproof when the angle between sprinkler heads and opening in the enclosure does not exceed 45° from the vertical.
2. Ventilated
3. ASA 61 grey
4. Floor/Wall mounting

Rev.	Remarks	By	Appr. By	Date
1	Enclosure Size Revised	AP	V.S	April 1, 2019

Prepared by: AP  
 Approved by: VS  
 Date: AUG.13, 2013